

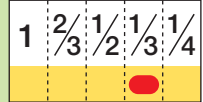

**For FA/Machine Vision**  
**3CCD Camera**

# TF2.8DA-8

Applicable camera (model)



**FIXED**  
Fixed Focal

**WIDE**  
Wide Angle

**3CCD**  
For 3CCD Camera

**MANUAL**  
Manual Iris

**C-mt**  
C Mount

**METAL**  
Metal Mount



- Special design for optimizing the image quality of 3CCD cameras.
- Low-distortion design achieving accurate image input.
- Compact, lightweight and robust design, supporting various systems.
- Faithful color reproduction for 3CCD cameras, best suited for advanced monitoring applications.

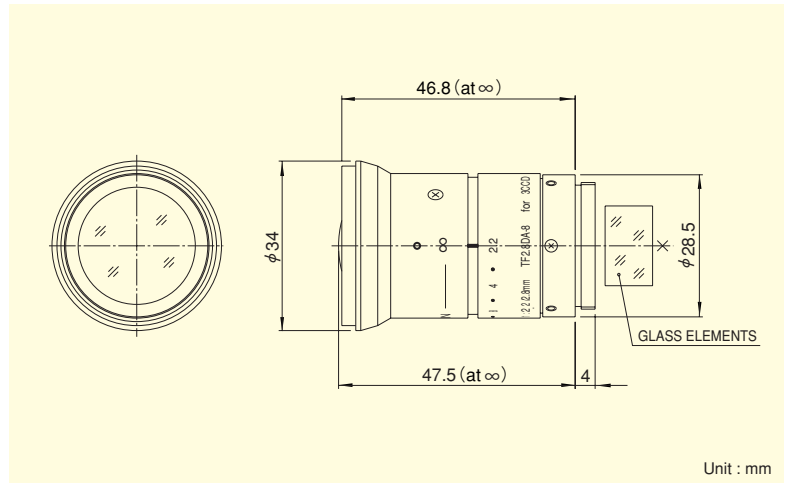

Focal Length (mm)		2.8
Iris Range		F2.2 ~ F16 · Close
Operation	Focus	Manual
	Iris	Manual
Angle Of View (H×V)	1/3"	89°08' × 69°20'
Focusing Range (From Front Of The Lens) (m)		∞ ~ 0.1
Object Dimensions at M.O.D. (H×V) (mm)	1/3"	218 × 153
Back Focal Distance (in air) (mm)		14.49
Exit Pupil Position (From Image Plane) (mm)		98
Filter Thread (mm)		—
Mount		C
Mass (g)		75
Remarks	•With Metal Mount	

3CCD CAMERA LENSES