

L-GATE Gateway LGATE-952

Datasheet #89023318

- ✓ BACnet
- ✓ Modbus
- ✓ CEA-709
- ✓ M-Bus
- ✓ KNX
- ✓ OPC

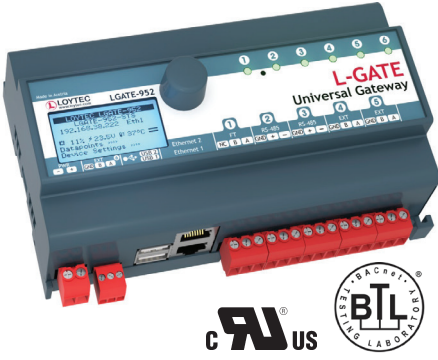

The L-GATE Gateway LGATE-952 are powerful universal gateways that can host user specific graphical pages to be used with LWEB-802/803. They can simultaneously integrate and map data points from multiple open protocols. Local operation and override is provided by the built-in jog dial and the backlit display (128x64 pixels). Device and data point information is provided by the web interface and shown on the display via symbols and in text format.

The powerful universal gateways provide connectivity functions to concurrently integrate CEA-709 (LonMark Systems), BACnet, KNX, Modbus, and M-Bus subsystems. LonMark Systems can be integrated via IP-852 (Ethernet/IP) or TP/FT-10. BACnet integration is supported through BACnet/IP (Ethernet/IP) or BACnet MS/TP (RS-485). LGATE-952 feature an integrated Remote Network Interface (RNI) to access the TP/FT-10 channel on the device via Ethernet/IP. LGATE devices implement the BACnet Building Controller (B-BC) profile, can be configured to be a BBMD and are BTL tested and WSPcert certified. In addition, the universal gateways provide connectivity to KNXnet/IP and Modbus TCP via Ethernet/IP and to Modbus RTU via RS-485. M-Bus and KNX TP1 device integration needs optional interface modules.

The gateway functionality allows data communication between all communication technologies available on the device. Different technology data points are mapped through Local Connections on the device. The mapping of different technology data points on distributed devices is supported by Global Connections. The universal gateways LGATE-952 also support Smart Auto-Connect™ – the automatic generation of connections to substantially reduce engineering efforts and cost. Optionally, mathematical objects can be applied within a connection to calculate the data point output values depending on the formula used. All technology data points are automatically created as OPC XML-DA and OPC UA data points.

Each LGATE-952 is equipped with two Ethernet ports. It can either be configured to use the internal switch to interconnect the two ports or every port is configured to work in a separate IP network.

When the Ethernet ports are configured for two separate IP networks, one port can be connected for instance to a WAN (Wide Area Network) with enabled network security (HTTPS) while the second port can be configured to be connected to an insecure network (LAN) where the standard building automation protocols like BACnet/IP, LON/IP, or Modbus TCP are present. These devices also feature firewall functionality of course to isolate particular protocols or services between the ports.

Using the internal switch, a daisy chained line topology of up to 20 devices can be built, which reduces costs for network installation. The IP switch also allows the setup of a redundant Ethernet installation (ring topology), which increases reliability. The redundant Ethernet topology is enabled by the Rapid Spanning Tree Protocol (RSTP), which is supported by most managed switches.

The L-GATE devices provide fully featured AST™ functionality (Alarming, Scheduling, and Trending) and can be integrated perfectly into the L-WEB System.

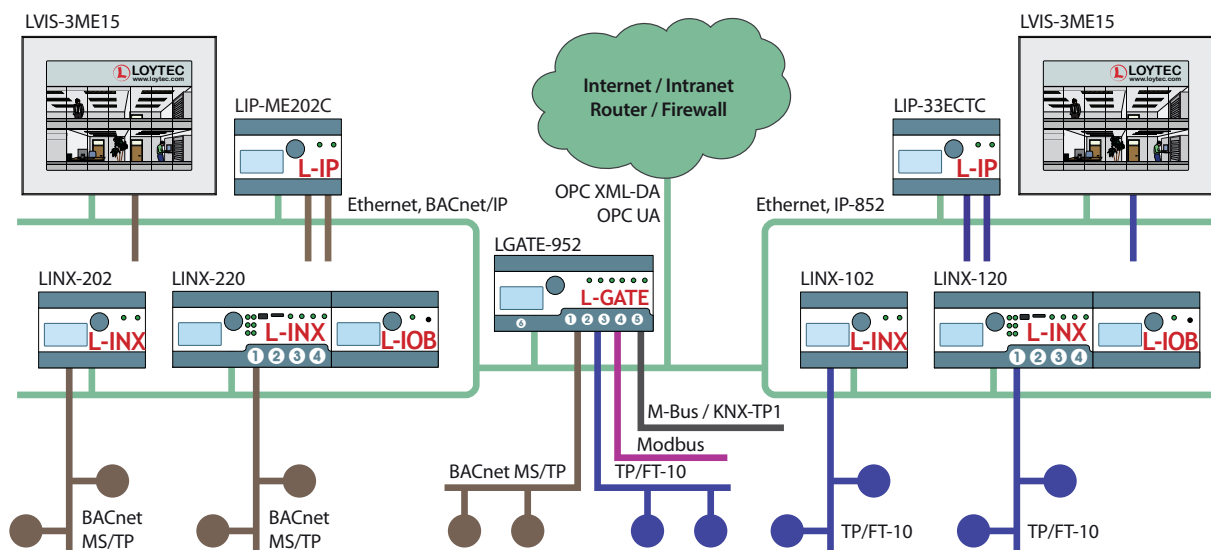

Features

- Universal gateway
- Compliant with ANSI/ASHRAE 135-2012 and ISO 16484-5:2012 standard
- B-BC (BACnet Building Controller) functionality
- Supports BBMD (BACnet Broadcast Management Device)
- Supports BACnet MS/TP or BACnet/IP
- BACnet Client Function (Write Property, Read Property, COV Subscription)
- BACnet Client Configuration with configuration tool (scan and EDE import)
- Compliant with CEA-709, CEA-852, and ISO/IEC 14908 Standard (LonMark System)
- Supports TP/FT-10 or IP-852 (Ethernet/IP)
- Support of dynamically created or static NVs
- Support of CEA-709 user-defined NVs (UNVTs) and Configuration Properties (SCPTs, UCPTs)
- Remote Network Interface (RNI) with 2 MNI devices
- Support of KNX/IP directly, KNX TP1 via LKNX-300 Interface
- M-Bus Master according to EN 13757-3, connection via optional M-Bus Converter (L-MBUS20 or L-MBUS80)
- Modbus TCP and Modbus RTU (Master or Slave)
- Automatic creation of Local Connections (Smart Auto-Connect™)
- Math objects to execute mathematical operations on data points
- Automatic mapping of network variables to BACnet objects in accordance with CEN/TS 15231:2005
- Alarming, Scheduling, and Trending (AST™)
- Event-driven e-mail notification
- Stores customized graphical pages
- Visualization of customized graphical pages through LWEB-900 and LWEB-802/803
- Built-in OPC XML-DA and OPC UA server
- Dual switched or separated Ethernet ports
- Access to network statistics
- Integrated web server for device configuration and monitoring data points
- Manual operation using the jog dial or VNC client
- Local and remote access to information about device status and data points
- 128x64 graphic display with backlight
- Configurable via Ethernet/IP or TP/FT-10
- Connection to EnOcean wireless devices via LENO-80x Interface
- Supports SMI (Standard Motor Interface) through LSMI-80x
- Supports WLAN through LWLAN-800 Interface
- Stores user-defined project documentation

Specifications

Type	LGATE-952
Dimensions (mm)	159 x 100 x 75 (L x W x H), DIM052
Installation	DIN rail mounting following DIN 43880, top hat rail EN 50022
Power supply	24 VDC / 24 VAC ±10 %, typ. 2.5 W
Operating conditions	0 °C to 50 °C, 10 – 90 % RH @ 50 °C, non condensing, degree of protection: IP40, IP20 (terminals)

L-GATE Gateway

LGATE-952

Specifications

Type	LGATE-952
Interfaces	2 x Ethernet (100Base-T): OPC XML-DA, OPC UA, LonMark IP-852*, BACnet/IP**, KNXnet/IP, Modbus TCP (Master or Slave), HTTP, FTP, SSH, HTTPS, Firewall, SNMP 1 x TP/FT-10* (LonMark System) 2 x USB-A: WLAN (needs LWLAN-800), EnOcean (needs LENO-80x), SMI (needs LSMI-804) 2 x RS-485 (ANSI TIA/EIA-485): BACnet MS/TP** or Modbus RTU (Master or Slave) 1 x EXT1: M-Bus, Master EN 13757-3 (needs L-MBUS20/80) 1 x EXT2: KNX TP1 (needs LKNX-300) 1 x EXT3: SMI (needs LSMI-800)
	* Either LonMark IP-852 or TP/FT-10 (no router) ** Either BACnet/IP or BACnet MS/TP (no router)
Tools	L-INX Configurator
Remote Network Interface	1 RNI with 2 MNI devices

Resource limits

Total number of data points	30 000	LonMark Schedulers	100
OPC data points	5 000	LonMark Alarm Servers	1
BACnet objects	1 000 (analog, binary, multi-state)	E-mail templates	100
BACnet client mappings	1 000	Math objects	100
BACnet calendar objects	25	Alarm logs	10
BACnet scheduler objects	100 (64 data points per object)	M-Bus data points	1 000
BACnet notification classes	32	Modbus data points	2 000
Trend logs (BACnet or generic)	512 (4 000 000 entries, ≈ 60 MB)	KNX TP1 data points	1 000
Total trended data points	1 000	KNXnet/IP data points	1 000
CEA-709 network variables (NVs)	2 000	Connections (Local / Global)	2 000 / 250
CEA-709 Alias NVs	2 000	Number of L-WEB clients	32 (gleichzeitig)
CEA-709 External NVs (polling)	2 000	Number of EnOcean devices	100
CEA-709 address table entries	1 000 (non-ECS mode: 15)	EnOcean data points	1 000
LonMark Calendars	1 (25 calendar patterns)	SMI devices (per channel)	16

Order number Product description

LGATE-952	Universal Gateway
LPOW-2415A	LIOB-Connect power supply unit, 24 VDC, 15 W
LPOW-2415B	Power supply unit with power connector 24 VDC, 15 W
L-MBUS20	M-Bus level converter for 20 M-Bus devices
L-MBUS80	M-Bus level converter for 80 M-Bus devices
LKNX-300	KNX interface to connect KNX TP1 devices
LENO-800	EnOcean Interface 868 MHz Europe
LENO-801	EnOcean Interface 902 MHz USA/Canada
LENO-802	EnOcean Interface 928 MHz Japan
LWLAN-800	Wireless LAN Interface IEEE 802.11bgn
LSMI-800	Standard Motor Interface for 16 motors via EXT port
LSMI-804	Standard Motor Interface for 64 motors, 4 SMI channels via USB