



## GST-FT24N Fire Telephone Panel

### Description

GST-FT24N fire telephone panel is specialized for emergency communication, builds up convenient and prompt 2-way communication in case of fire and other abnormal conditions. It is an indispensable device in fire protection system.

### Features and Benefits

- 19" Rack mount installation
- 24VDC power supply
- 24 zones, conventional connection
- Receiving and calling out with fire telephone handsets
- Networkable fire telephone panels achieve internal communication
- Call from handset will be transferred to networked fire telephone panels automatically after not answered by the dedicated panel
- The handset zones are fully monitored for fault of short circuit and open circuit. Panel will show the fault by sound and indicator.
- Failure of one zone will not affect other zones
- Network communication monitored.

### Installation Data

GST-FT24N is rack-mount type. Its appearance and the dimensions are shown here.

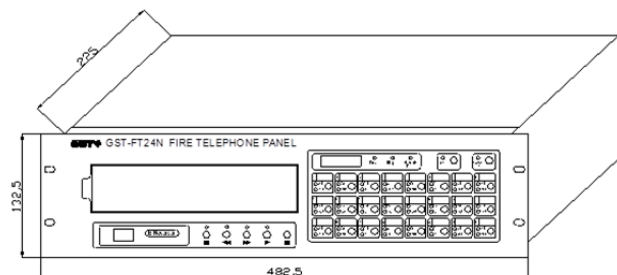

### Recommended Cabling

1.5mm<sup>2</sup> or above fire cable is recommended for 24VDC, 1.0mm<sup>2</sup> or above twisted-pair fire cable is recommended for others.

All cables should be subject to local codes.

## Terminals

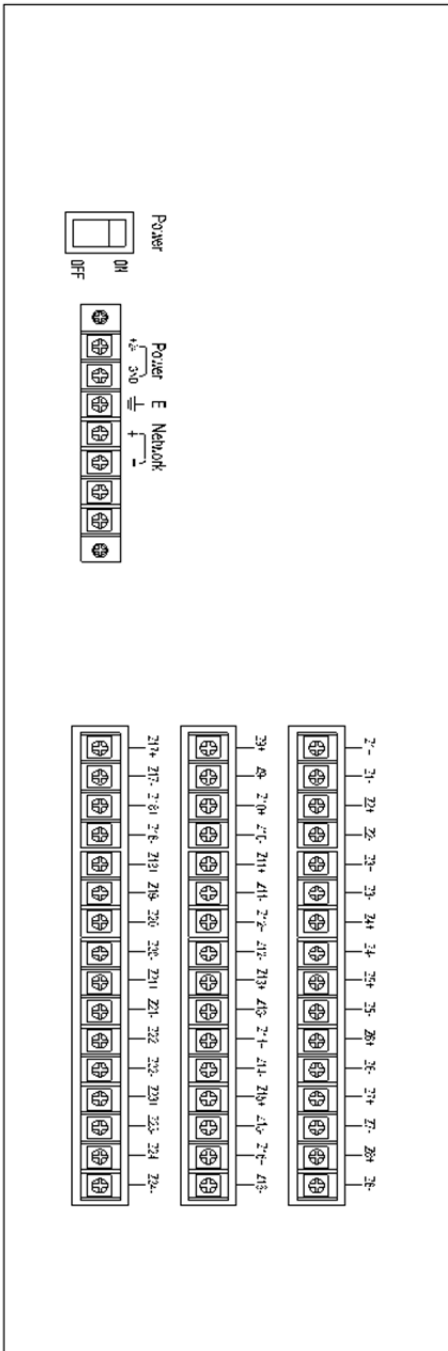

Power (+24, GND): 24VDC power in, polarized

E: Earth

Network (+, -): Network, polarized

Zn+, Zn-: Zone Terminals, connecting with handsets (an EOLR of 10KΩ±0.5KΩ is required to the last point of each zone).

## Application

The typical connection of system is shown below.

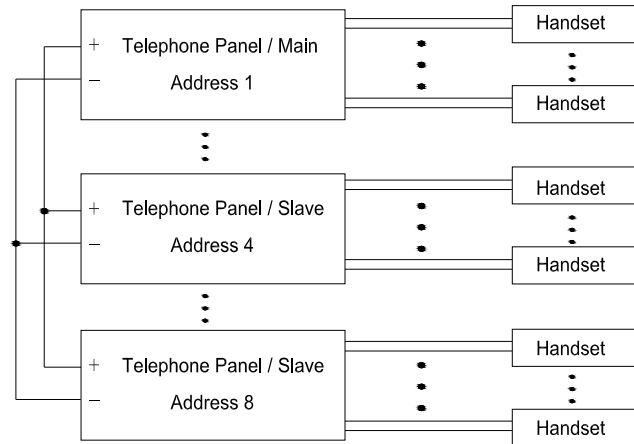

## Technical Specification

Operating Voltage	24VDC±10%
Standby Current	0.2A
Maximum Current	1A
Frequency Range	300 ~ 3400Hz
Crosstalk	<-60dB
Transmission Loss	<5dB
Environment Temperature	-5~40°C
Relative Humidity	45%~95%
Dimension	482.5mm × 132.5mm × 225mm
Gross Weight	4.2kg

## Order Information

Part No.	GST-FT24N
Device Name	Fire Telephone Panel
Order Code	5321287
Compatible Devices	P-9911(F) Fixed Fire Telephone Handset P-9911(H) Hand-free Fire Telephone Handset P-9911(J) Fire Telephone Jack P-9911(M) Mobile Fire Telephone Handset