

4 MP and 4K (12 MP) Zoom Lenses

HLM27V12MPD / HLM5V50MPD /
HLM37V16MPD / HLM105V42MPD

Honeywell is taking quality and reliability to the next level with the equiP® family of lenses and accessories. The Honeywell box camera lenses can be used to install the equiP® line of IP cameras to a variety of surveillance environments to cover a number of distances at high resolution. This lens family enables high definition cameras to maintain clear focus for all focal lengths within the zoom range, under both natural and near-infrared lighting conditions.

Today's network IP camera systems demand compact lenses that provide the best optical performance while being easy to install and adjust. Designed especially for low light capability, this lens family offers the most compact size in the market while maintaining the widest maximum apertures for a given focal length range. It offers the ability to provide a high contrast, sharp, detailed picture of the subject in daylight and in low light, allowing identification of a subject rather than just observation.

Featuring world-class design, these megapixel lenses bring together the highest quality aspheric glass optics, lightweight construction, and durability to ensure state-of-the-art optical correction, transmission, and light-gathering ability.

Vari-focal length lenses allow the installer to quickly and easily obtain the exact field of view, eliminating lens substitutions or the need to continuously adjust the camera setup. This is especially convenient for future changes to the viewing environment.

Market Opportunities

Lens selection is the most critical element in any IP Network CCTV installation. Honeywell's complete line of IR Corrected Vari-focal lenses provides the highest quality, reliability and ease of installation. In addition to extraordinary low-light functionality, Honeywell's day/night lenses are compact, lightweight, and easy to install, making them perfect for use with True Day/Night cameras. The day/night vari-focal lenses are ideal in outdoor installations (outdoor housing required) such as parking lots, ports, and other areas where low light imaging is important.



HLM27V12MPD



HLM5V50MPD



HLM37V16MPD



HLM105V42MPD

FEATURES AND BENEFITS

- 4 MP and 12 MP performance offers the ability to provide a high contrast, sharp detailed picture of the subject in daylight and low light, allowing identification of a subject rather than just observation
- Focal length ranges from 2.7 - 12 mm, 5 - 50 mm, 3.7 - 16 mm, or 10.5 - 42 mm,
- Uniform focus under both natural and near-infrared lighting conditions
- High-accuracy aspheric glass lens having a low dispersion and a high-refractive index for optimum performance
- IR corrected Vari-focal lens ensures that focus shift does not occur when the camera switches between color and monochrome modes
- Equipped with a CS-type metal mount
- Lightweight and compatible with 1/3", 1/2.7" and 1/2.8" type image sensors

4 MP and 4K (12 MP) Zoom Lenses

DIMENSIONS

HLM37V16MPD

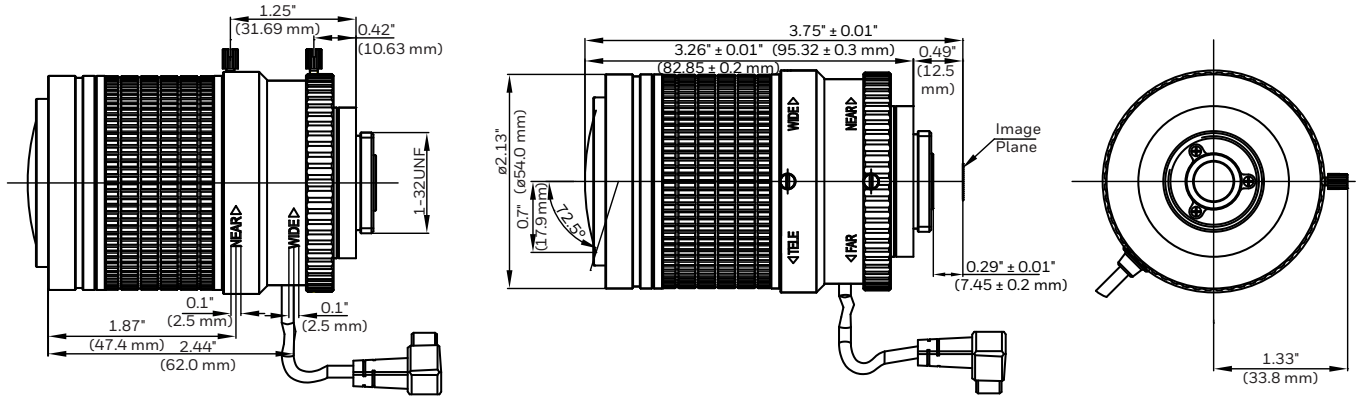

HLM105V42MPD

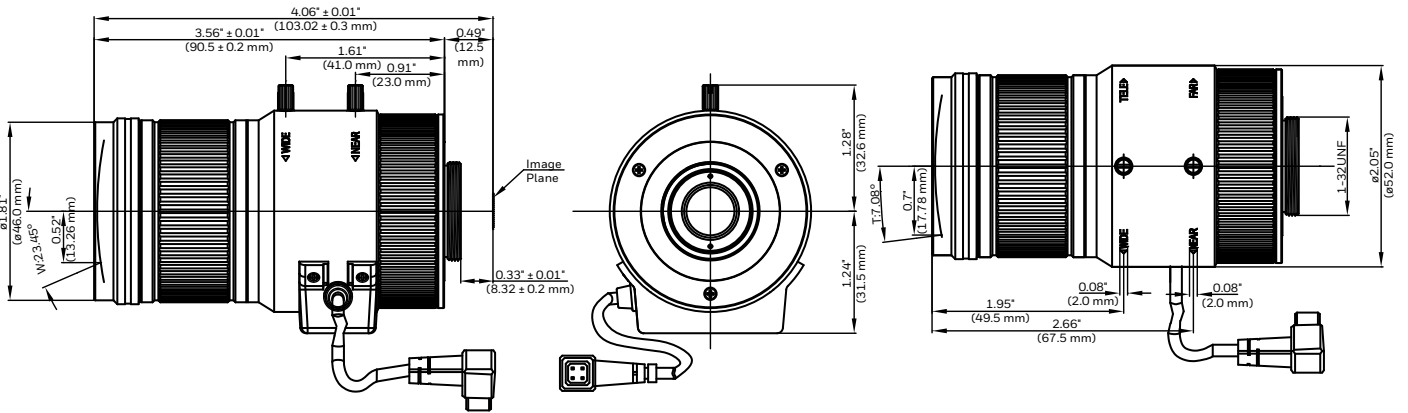

HLM27V12MPD

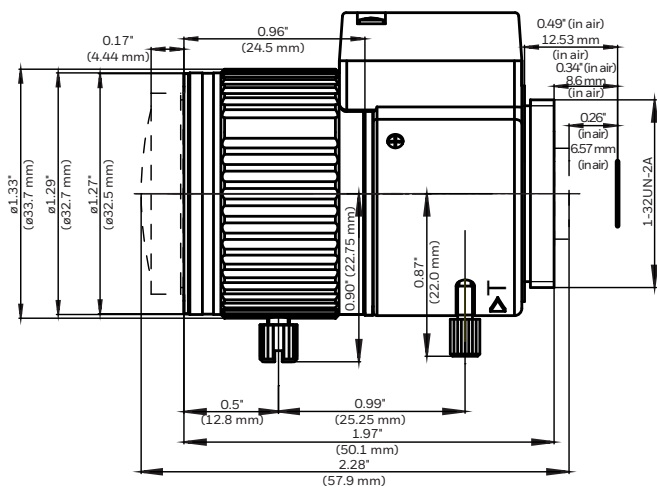

HLM5V50MPD

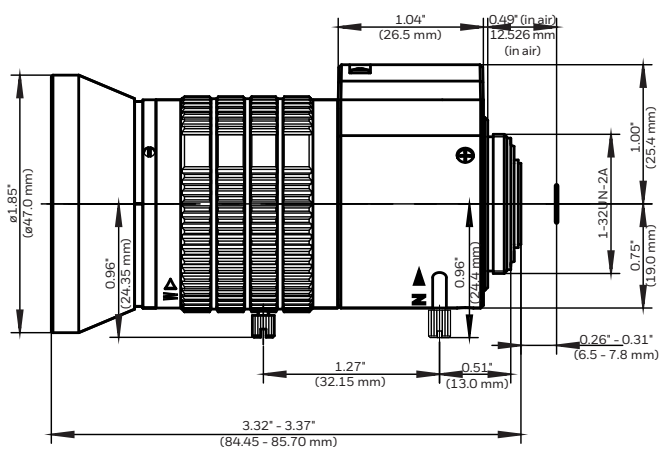

4 MP and 4K (12 MP) Zoom Lenses

SPECIFICATIONS

LENSES		HLM27V12MPD	HLM5V50MPD	HLM37V16MPD	HLM105V42MPD
OPERATIONAL					
IMAGE FORMAT		1/2.7"	1/2.7"	1/1.7"	1/1.7"
LENS MOUNT		CS (Metal mount)	CS (Metal mount)	CS (Metal mount)	CS (Metal mount)
FOCAL LENGTH		2.7 – 12.0 mm	5.0 – 50.0 mm	3.7 – 16.0 mm	10.5 – 42.0 mm
APERTURE		F1.6	F1.6	F1.5	F1.5
FOCUS RANGE (MOD)		0.3 m	1 m	0.5 m	0.3 m
ANGLE OF VIEW	WIDE	137.8° X 102.6° X 74.3°	70° X 50° X 37.5°	145° X 109° X 79°	46.9° x 37.2° x 27.6°
	TELE	37.2° X 29.9° X 22.6°	7° X 5.6° X 4.2°	35.6° X 28.5° X 21.4°	14.2° x 11.2° x 8.4°
BACK FOCUS DISTANCE (W – T)		7.05 – 14.8 mm	7.91 – 10.48 mm	7.92 – 18.26 mm	10.2 – 13.1 mm
IRIS RANGE		Φ 7.2	Φ 9.5	Φ 11.4	Φ 16.0
LENS CONTROL	FOCUS	Manual	Manual	Manual	Manual
	ZOOM	Manual	Manual	Manual	Manual
	IRIS	DC-IRIS	DC-IRIS	DC-IRIS	DC-Iris
ELECTRICAL					
COIL RESISTANCE	DRIVE COIL	190Ω±10% (at 20°C)	190Ω±10% (at 20°C)	190Ω±10% (at 20°C)	190Ω±10% (at 20°C)
	DAMPLING COIL	560Ω±10% (at 20°C)	855Ω±10% (at 20°C)	860Ω±10% (at 20°C)	500Ω±10% (at 20°C)
MECHANICAL					
DIMENSIONS (L X W)		ø1.33" X 2.27" (ø33.7X 57.6 mm)	ø1.85" X 3.38" (ø47.0 X 85.9mm)	ø2.13" X 3.26" (ø54.0 X 82.8 mm)	ø2.05" x 3.56" (ø52.0 x 90.5 mm)
WEIGHT		0.16 lb (0.0735 kg)	0.43 lb (0.195 kg)	0.6 lb (0.27 kg)	0.71 lb (0.32 kg)
CONSTRUCTION (HOUSING)		Aluminum	Aluminum	Aluminum	Aluminum
ENVIRONMENTAL					
TEMPERATURE	OPERATING	-22°F ~ 158°F (-30°C ~ 70°C)	-22°F ~ 158°F (-30°C ~ 70°C)	-22°F ~ 158°F (-30°C ~ 70°C)	-22°F ~ 158°F (-30°C ~ 70°C)
	STORAGE	-22°F ~ 158°F (-30°C ~ 70°C)	-22°F ~ 158°F (-30°C ~ 70°C)	-22°F ~ 158°F (-30°C ~ 70°C)	-22°F ~ 158°F (-30°C ~ 70°C)
RELATIVE HUMIDITY		10% ~ 95% RH	10% ~ 95% RH	10% ~ 95% RH	10% ~ 95% RH
REGULATORY					
EMC		CE/FCC/RCM	CE/FCC/RCM	CE/FCC/RCM	CE/FCC/RCM

ORDERING

HLM27V12MPD	4 MP, 1/2.7", F1.6, 2.7 – 12.0 mm CS Lens
HLM5V50MPD	4 MP, 1/2.7", F1.6, 5.0 – 50.0 mm CS Lens
HLM37V16MPD	12 MP, 1/1.7", F1.5, 3.7 – 16.0 mm CS Lens
HLM105V42MPD	12 MP, 1/1.7", F1.5, 10.5 – 42.0 mm CS Lens

NOTE: Honeywell reserves the right, without notification, to make changes in product design or specifications.

For more information

www.honeywell.com/security

Honeywell Security and Fire

2 Corporate Center Dr. Suite 100

P.O. Box 9040

Melville, NY 11747

1.800.323.4576

www.honeywell.com

L/EIPCLD/D | 08/16
© 2016 Honeywell International Inc.

Honeywell